

Sweat Bee® utilizes industrial components and an efficient motor to eliminate uncomfortable working conditions.

TAKE THE STING OUT OF WORKPLACE HEAT

- **Sizes** — Available in 18- (457 mm) and 30-inch (762 mm) models
- **Construction** — Barrel made from durable 11 gauge steel with zinc-plated, OSHA-compliant spiral guards; Corrosion-resistant surfaces
- **Blades** — Made from glass-reinforced polyamide (18-inch model) or glass-reinforced polypropylene (30-inch model); statically and dynamically balanced for lasting performance
- **Power Supply** — 12-foot (3.7 m) cord with 3-prong, grounded plug fits into standard power outlets (18-inch model only); includes on/off switch for convenient operation
- **Motor** — Ball bearing motor precisely matched to hub assembly for superior performance and reliability
- **Color** — Signal yellow, industrial-grade powder coat
- **Mounting Options** — Wall/column mount or swivel arm; portable base and pedestal available with 18-inch model only



Technical Specifications

Model	Fan size	Input power and breaker	Max current	Max speed	Sound level at max speed ¹	Weight ²	Motor	Air velocity ³
Sweat Bee 18	18 in. (457 mm)	100–125 VAC, 1 Φ , 60 Hz, 20 A	6 A	1725 RPM	81 dBA	78 lb (35.4 kg)	1/3 hp (0.25 kW)	410–123 fpm (125–37 mpm)
Sweat Bee 30	30 in. (762 mm)	200–250 VAC, 3 Φ , 15 A	3.7 A	1160 RPM	87 dBA	125 lb (56.7 kg)	1 hp (0.75 kW)	629–191 fpm (192–58 mpm)
		400–480 VAC, 3 Φ , 15 A	1.9 A					

¹ Fans are sound tested at maximum speed in a laboratory environment. Actual results in field conditions may vary due to sound reflecting surfaces and environmental conditions.

² Fan and yoke. Add 9 lb (4 kg) if using the wall/column mount with an 18-in. (457-mm) fan. Add 15 lb (6.8 kg) if using the wall/column mount with a 30-in. (762-mm) fan. Add 31 lb (14 kg) if using the portable base and pedestal with an 18-in. (457-mm) fan.

³ Measured to 100 ft (30.5 m) for 18-in. (457-mm) fans; measured to 140 ft (42.7 m) for 30-in. (762-mm) fans

Sweat Bee 18

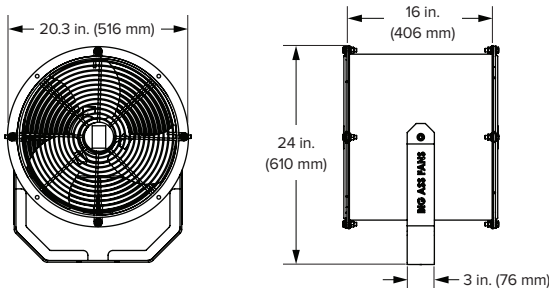

Sweat Bee 30

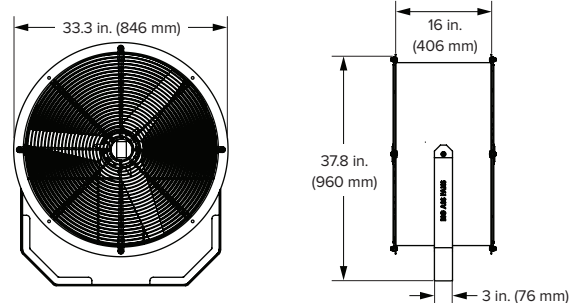

Wall/Column Bracket

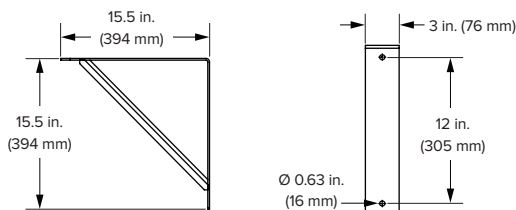

Wall/Column Bracket

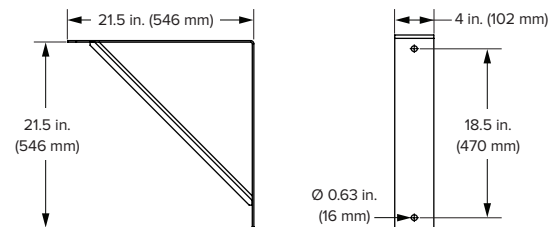

See full warranty for coverage information.
Specifications subject to change without notice.

Perfect for loading docks, the Sweat Bee® Swivel Mount lets you easily swing the fan from door to door or out of the way of truck traffic in aisles, giving you complete control of airflow direction.

TAKE THE STING OUT OF WORKPLACE HEAT

- **Application** — Perfect for loading docks
- **Heavy Duty Construction** — Barrel made from durable 11 gauge steel with zinc-plated, OSHA-compliant spiral guards; corrosion-resistant surfaces
- **Blades** — Made from high-density, glass-reinforced polyamide; statically and dynamically balanced for lasting perfect performance
- **Power Supply** — 12-foot (3.7 m) cord with 3-prong, grounded plug fits into standard power outlets (18-inch model only); includes on/off switch for convenient operation
- **Motor** — 1/3 hp (0.25 kW) ball bearing motor precisely matched to hub assembly for superior performance
- **Color** — Signal yellow, industrial-grade powder coat



Technical Specifications

Fan size	Input power and breaker	Max current	Max speed ¹	Sound level at max speed ²	Weight	Motor
18 in. (457 mm)	100–125 VAC, 1 Φ, 60 Hz, 20 A	6 A	1725 RPM	81 dBA	94 lb (42.6 kg)	1/3 hp (0.25 kW)
	200–250 VAC, 1 Φ, 60 Hz, 15 A	3 A				

¹ Speed shown is nominal. Performance is based on actual speed of test.

² Measured 5 ft (1.5 m) from fan. Fans are sound tested at maximum speed in a laboratory environment. Actual results in field conditions may vary due to sound reflecting surfaces and environmental conditions.

Fan without Mount

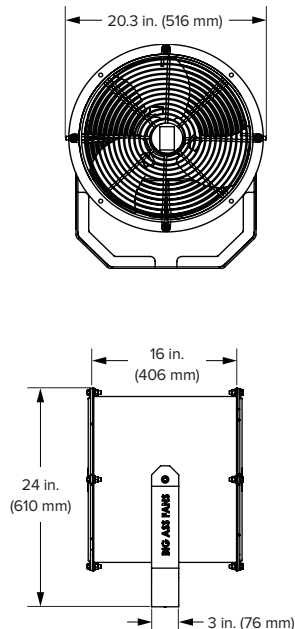

Fan with Swivel Mount

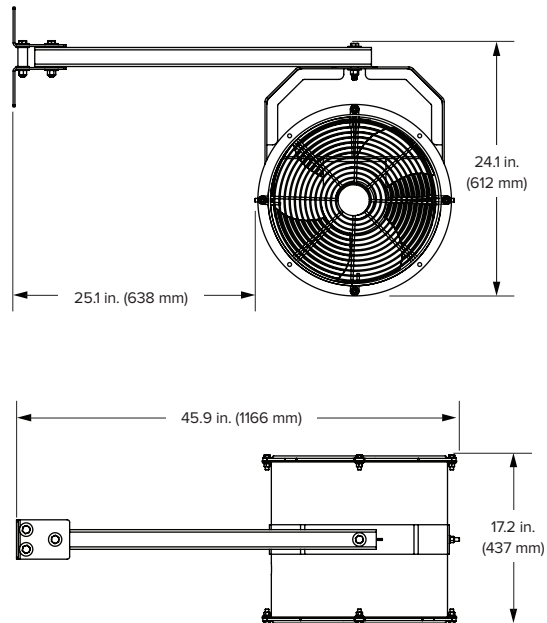

See full warranty for coverage information.
Specifications subject to change without notice.



AMERICAS
BIGASSOLUTIONS.COM
877-244-3267

CANADA
BIGASSOLUTIONS.COM/CA
844-924-4277

AUSTRALIA
BIGASSOLUTIONS.COM/AU
1-300-244-277

HONG KONG
BIGASSOLUTIONS.COM/HK
+852 2836 5808

SINGAPORE
BIGASSOLUTIONS.COM/SG
+65 6709 8500

MALAYSIA
+603 5565 0888